

Modeling Trade offs between Costs, Reliability and Air Emissions for Data Centers

Prof. David W. Coit
Prof. Frank A. Felder
Hatice Tekiner

May, 2009

Project team

Center for Energy, Economic & Environmental Policy
(CEEEP)

Bloustein School of Planning & Public Policy
Rutgers University

Participants: Frank Felder, Andrew Cottrell

Industrial & Systems Engineering
School of Engineering
Rutgers University

Participants: David Coit, Hatice Tekiner

We acknowledge the support of the Rutgers Energy Institute

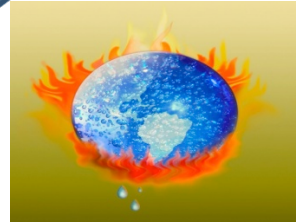

Electricity demand is increasing!

So the problems if ignored!



Data centers can consume 25 to 50 times as much electricity as standard office spaces

- A facility used to house mission critical computer systems and associated components for companies and organizations
- Includes environmental controls (air conditioning, fire suppression, etc.), redundant/backup power supplies, redundant data communications connections and high security



Data centers accounts for 1.5% of US electricity consumption and have the highest growth rate (it is expected to double by 2011)

Impacts of data centers on power grid

- Economic goals
 - Expansion plans
 - Reliability of power grid
 - Electricity network operations
- Societal goals
 - Greenhouse gas emissions (CO_2)
 - Pollutant emissions (NO_x , SO_2)

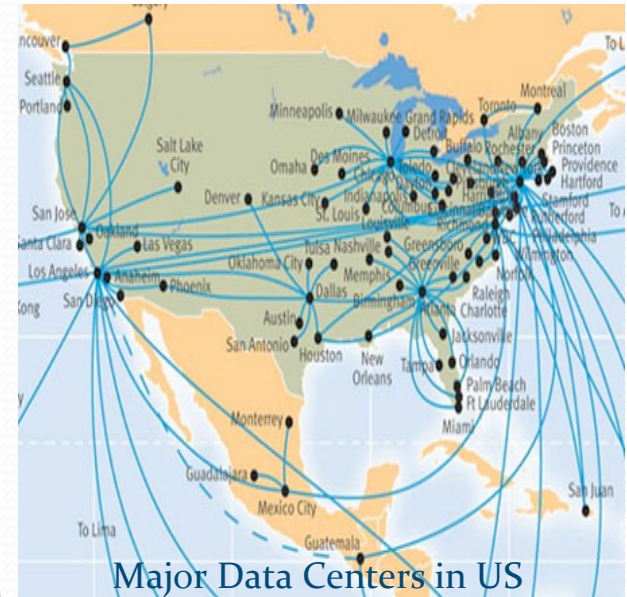

Research agenda

1. Analyze effects of data centers on grid
 - Electricity cost
 - Environmental footprint (CO₂, NO_x and SO₂ emissions)
 - Reliability
2. Optimize the design and operations of data centers
(cooling system, power supply, backup system)
3. Design/optimize interactions between data centers
(cooling system, power supply, backup system)

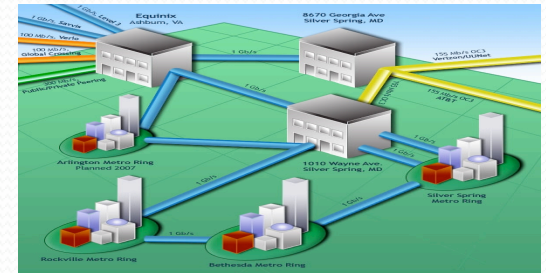

Technologies available to expand power grid

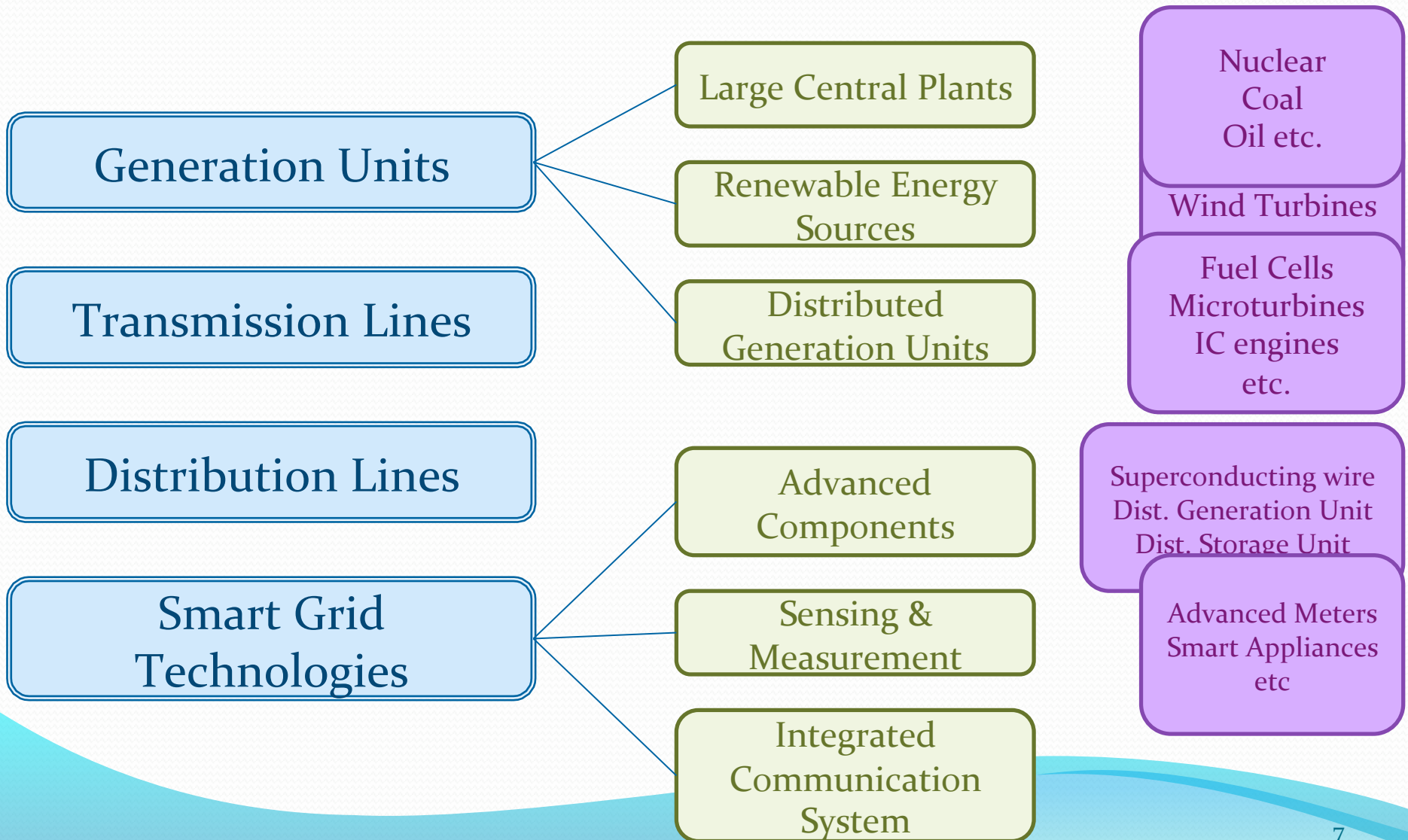

Technologies considered for expansion

Large Central Plants

- Nuclear
- Coal
- Oil
- Combined Cycle Gas Turbines

Renewable Energy Sources

- Wind Turbines



Smart Grid Technology

- IC engines as dist. generation unit

Distribution lines

- where the data centers are located

Expansion planning problem

Objectives

Minimization of
cost

Investment Cost
O&M Cost
Fuel Cost

Maximization of
reliability

Minimization of Unmet
Demand Cost

Minimization of
gas emission

CO₂ and NO_x



How to expand electric power system to provide **economic, reliable and green** electricity?

Solve an expansion planning problem

- to provide trade off solutions between the costs, reliability and emission
- to analyze the effects of **data centers** in overall electric system

What is expansion planning problem?

Determination of

- what type of technology to invest
- when & where to built the new technologies

to meet the future demand over a planning horizon

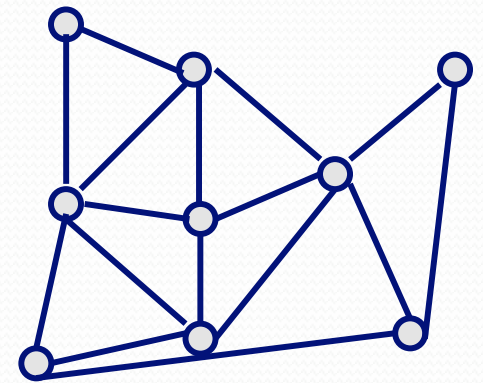

Multi-Objective stochastic optimization approach to determine expansion planning

Mathematical model is developed

- to integrate expansion, dispatching and reliability
- to provide trade-offs solutions with respect to cost, reliability, and gas emissions

References:

1. Tekiner, H., Coit, D., Felder, F., Multi-objective Power Generation Expansion Planning Problem with Monte Carlo Simulation, INFORMS, 2008
2. Tekiner, H., Coit, D., Felder, F., Solving the Single-period Multi-objective Power Generation Expansion Planning Problem, Proceedings of the 2009 Industrial Engineering Research Conference
3. Tekiner, H., Coit, D., Felder, F., Multi-period Multi-objective Electricity Generation Expansion Planning Problem with Monte Carlo Simulation (under review)

Example for existing system

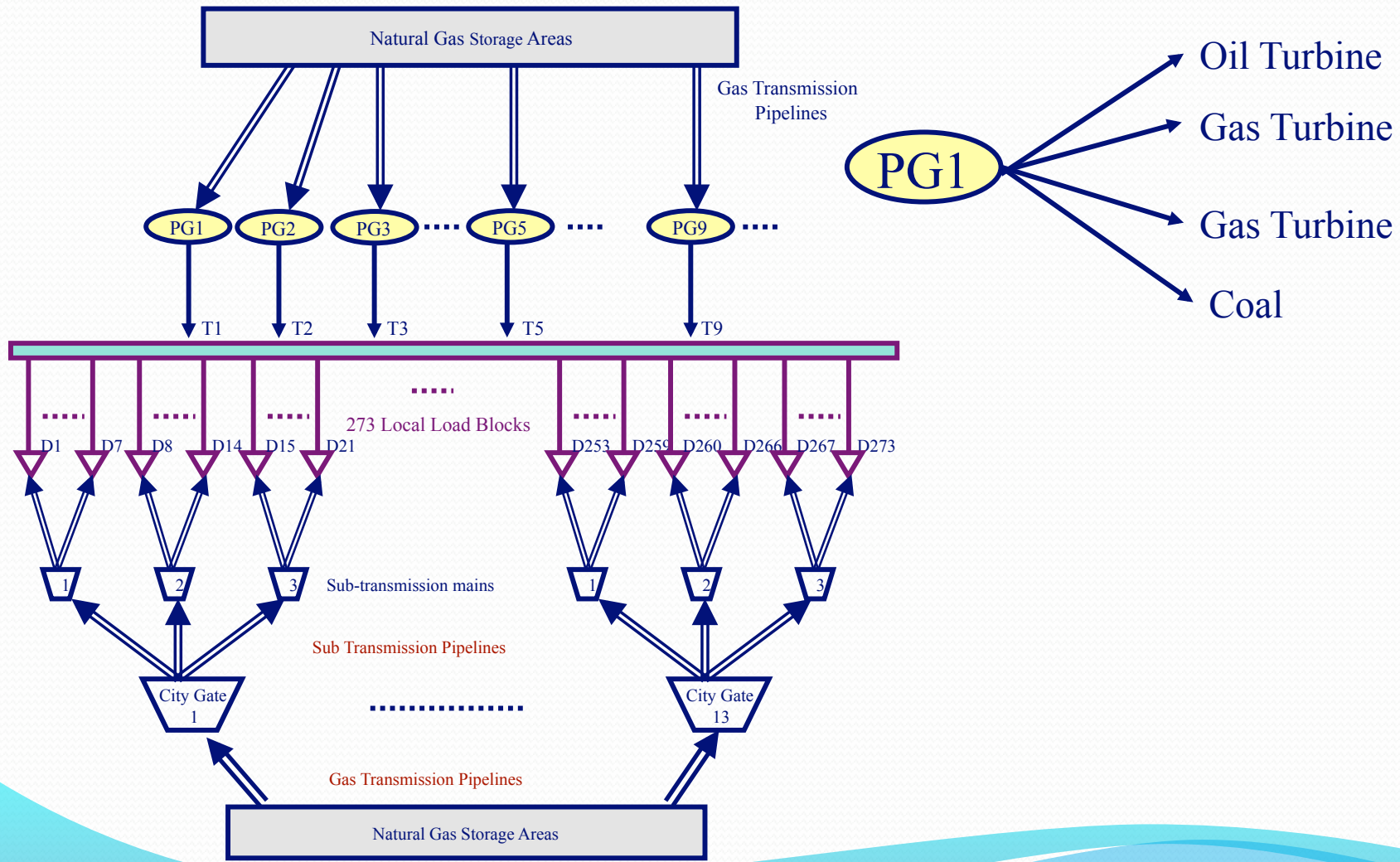

Existing system with data centers

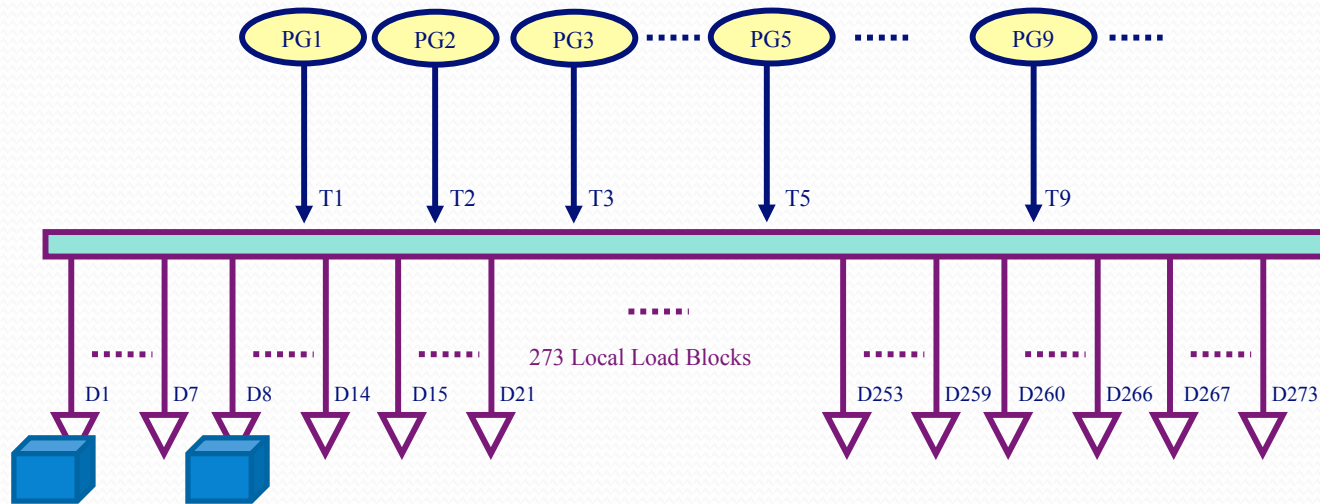

Peak load demand at each block = 10.5MW

Demand of each data center = 5MW

System peak load demand = 2876.5MW

Installed Capacity = 3450MW ($\approx 20\%$ reserve)

How to represent the electricity demand of the system

Load duration curve is partitioned

The center of each partition is used to represent the demand throughout the time of that partition.

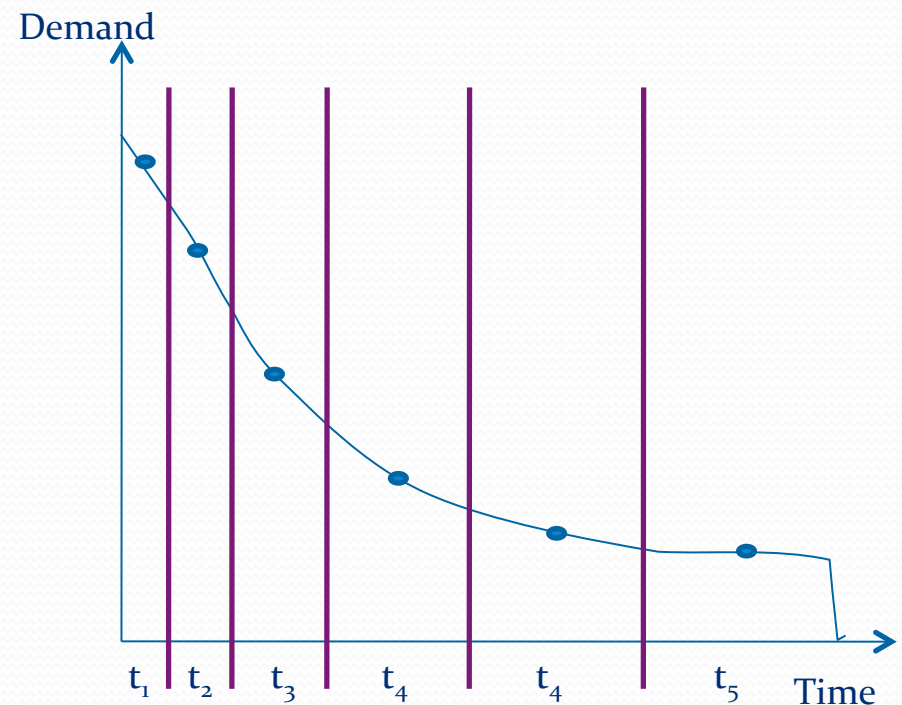

Objective function values with/without data centers

Objective:
Minimizing the cost

	Total Cost (billions of dollar)	CO ₂ (Thousands of tons)	NO _x (Thousands of tons)	SO ₂ (Thousands of tons)
with data centers	8.748	69,973	148	445
without data center	8.718	69,473	147	443

Data centers increase

Cost by \$332,000 (0.4%)

CO₂ emission by 500,000 tons (0.7%)

NO_x emission by 1,216 tons (0.8%)

SO₂ emission by 2,458 tons (0.6%)

Planning horizon is 8 years & reliability for data centers is
0.9999

Data Centers AFFECTs the reliability of the local demand

Reliability for Data Center	Reliability for Local Demand
1	0.9975
0.99999	0.9976
0.9999	0.9977
0.999	0.9980
0.99	0.9984

Increase in Data Center Reliability



Decrease in Local Demand Reliability



Additional distribution line is constructed if at least 0.999 of local demand should be satisfied

	Total Cost (billions of dollar)	CO ₂ (Thousands of tons)	NO _x (Thousands of tons)	SO ₂ (Thousands of tons)
with constraint	8.751	69,977	148	445
without constraint	8.748	69,973	148	445

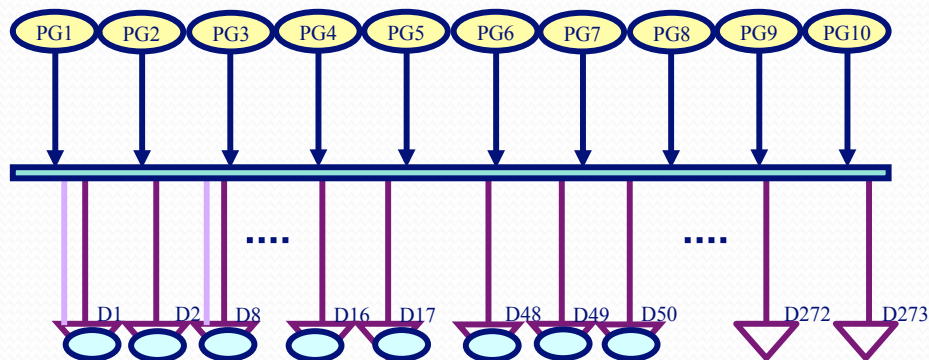

Unmet local demand & unmet data center demand is decreased, so the cost for unmet demand

Trade off solutions with respect to Cost , CO₂ and NO_x emissions

Decreasing importance of cost

Importance of	Total Cost (billions of dollar)			CO ₂ (Thousands of tons)	NO _x (Thousands of tons)	SO ₂ (Thousands of tons)
	Cost	CO ₂	NO _x			
1	0	0	8.748	69,973	148	445
0.8	0.2	0	9.404	46,968	148	79
0.8	0	0.2	9.128	54,722	78	243
0.8	0.1	0.1	9.247	52,722	71	217
0.5	0.5	0	10.11	41,459	75	39
0.5	0	0.5	10.09	43,923	40	83
0.5	0.25	0.25	10.09	43,923	40	83

Dispatching and expansion decisions are changing according to the importance of the objectives

TRADE-OFF between Cost , CO₂ and NO_x

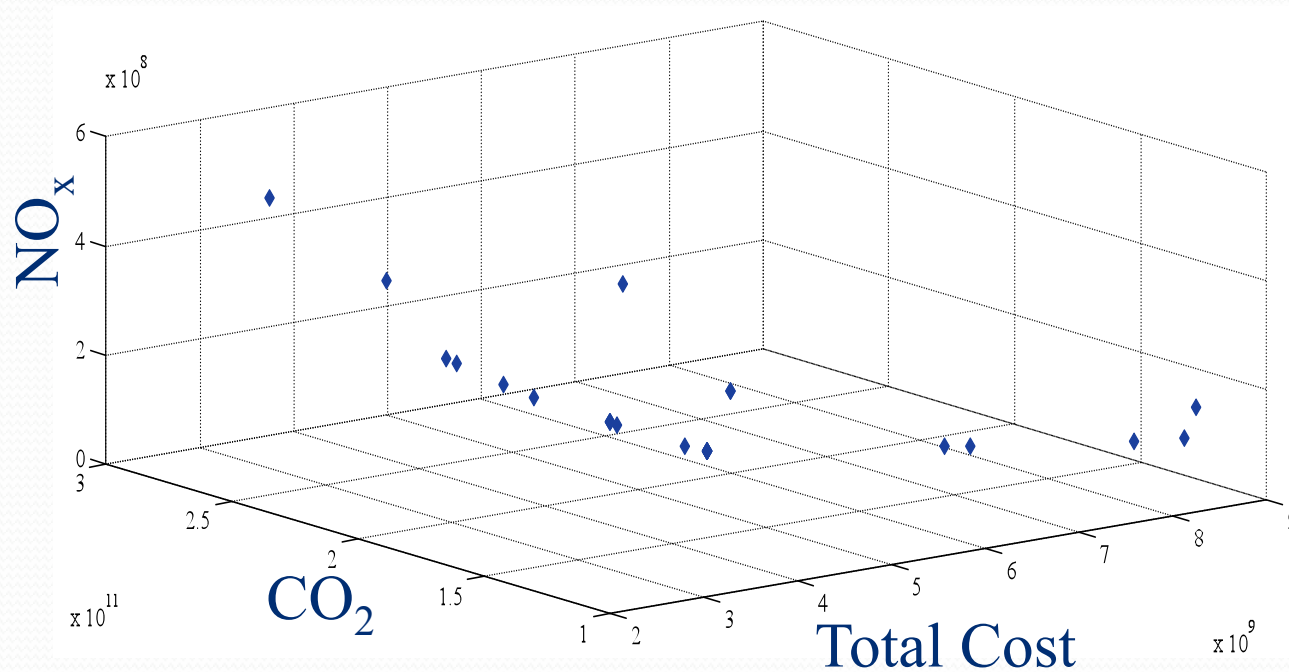

When minimizing CO₂ is high priority,
wind turbines & nuclear plant are introduced

Year 0;

Objective:
Minimizing the cost and CO₂

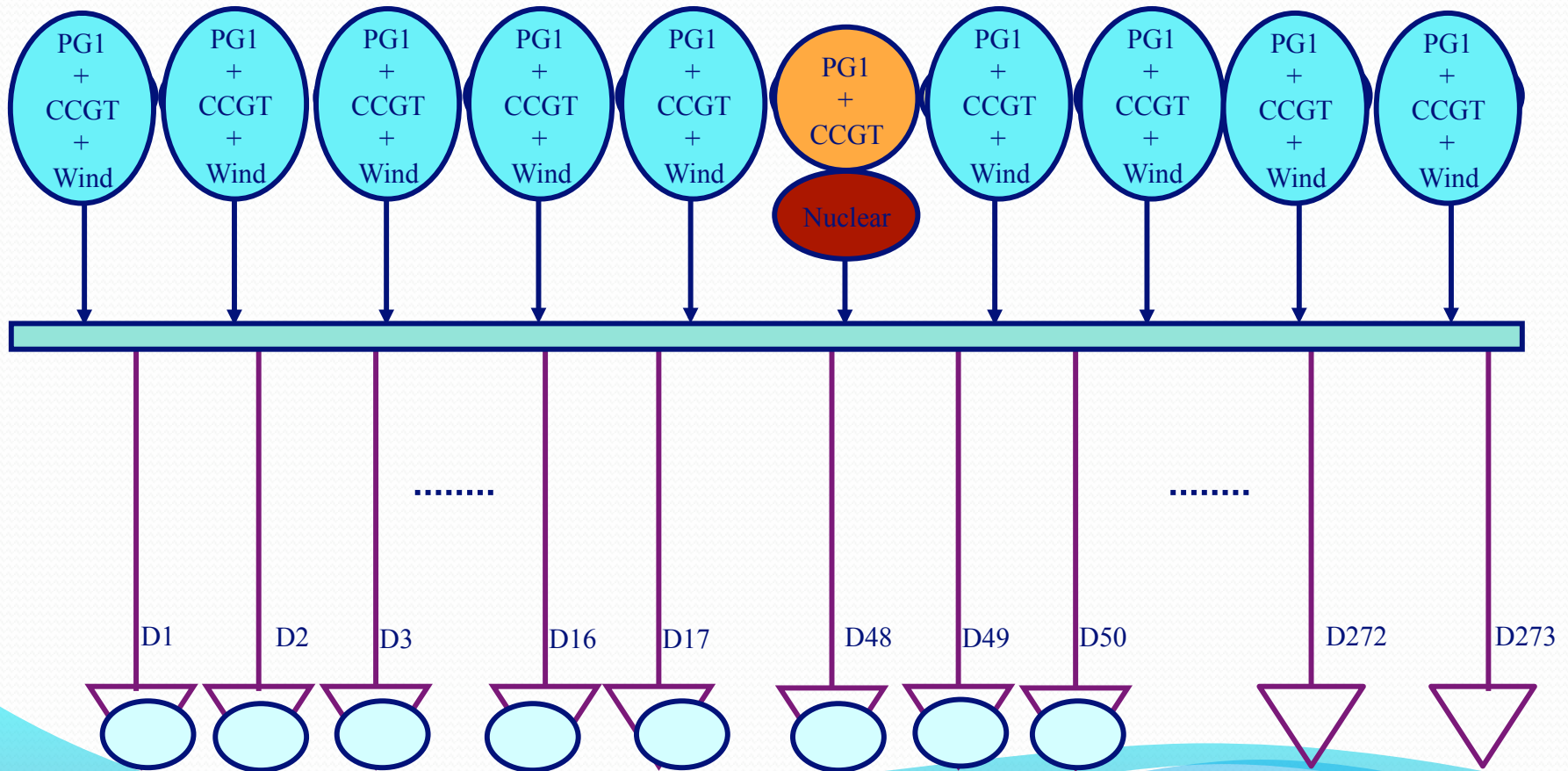

Ongoing research

1. Analyze effects of data centers on grid
 - Electricity cost
 - Environmental footprint (CO₂, NO_x and SO₂ emissions)
 - Reliability
2. Optimize the design and operations of data centers
(cooling system, power supply, backup system)
3. Design/optimize interactions between data centers
(cooling system, power supply, backup system)

THANK YOU